

APPC 1730T/1731T

17" TFT SXGA 4:3 Flush Panel PC with Intel® Atom™ D2550, 1.86GHz, Touch Screen, 1GB DDR3, 4xUSB, 4xCOM and VGA



Main Features

- 4:3 17" Fanless Panel Computer
- Intel® Atom™ D2550, Dual Core, Low Consumption CPU
- Flush Panel by 5-wire Touch Screen
- Dual GbE/ 2nd display-VGA/ Line-in/ MIC-in/ PS2 KB/MS
- USB x 4/ 2 x mini-PCIe sockets/ 1 x CFast/ 2 x RS232/ 422/ 485
- Optional 3.5G / Wi-Fi Module / 2.5" HDD / 2 x COMs / GPIO / DIO
- DDR3 1GB / 2.5" HDD Bracket
- IP65 Compliant Front Panel
- Mounting Support: Panel/ Wall/ Stand/ VESA 100mm x 100mm
- Wide Range Power Input 12V~ 30V DC

Product Overview

The 17" fanless panel PC APPC 1730T/1731T incorporating an industrial motherboard is intended for versatile industrial applications. The panel PC has a touch screen LCD panel with 1280x1024 (SXGA) resolution and 380-nit brightness. The front panel which adopts flush design and complies with IP65 standard makes it the perfect fit in industrial applications.

The APPC 1730T/1731T supports WWAN/WLAN expansion and others via dual Gigabit Ethernet connectors, two mini-PCIe slots and one SIM card holder. With support for wide power input of 12V~30V, APPC 1730T/1731T can gain a strong foothold in industrial field and machine devices. In addition, APPC 1730T/1731T can hook 2nd display via a VGA port for dual independent display. APPC 1731T has two isolated RS232/422/485 ports, two RS232 ports supporting 5V and 12V power feed, four isolated channels of DI and DO, and two channels of GPI and GPO.

Specifications

Panel

- LED Size: 17", 4:3
- Resolution: SXGA 1280x1024
- Luminance: 380cd/m2
- Contrast ratio: 1000
- LCD color: 16.7M
- Viewing Angle: 80(U), 80(D), 85(L), 85(R)
- Backlight: CCFL

Touch

- Touch screen: 5-wire resistive (flush panel type)
- Touch light transmission: 81%
- Touch interface: USB

System

- CPU: On-board Intel® Atom™ Dual Core processor D2550, 1.86GHz, 1M L2 Cache
- BIOS: AMI BIOS
- System chipset: Intel® NM10 Express chipset
- System memory: 2x 204-pin DDR3 SO-DIMM socket, 1G DDR3 (Default),
- Support up to 4GB DDR3-800/1066, Non-ECC and Un-buffered

- Storage Device:
 - 1x external locked CFast socket
 - 1x hard drive bay: optional 1x 2.5" SATA HDD or 1x SATA DOM
- Watchdog timer: Watchdog timeout can be programmable by software from 1 second to 255 seconds and from 1 minute to 255 minutes (Tolerance 15% under room temperature 25°C)
- H/W status monitor: Monitoring system temperature, and voltage
- Expansion: 2x Mini-PCIe sockets (support optional WiFi or 3.5G module)
- Panel backlight control button: Increase brightness / decrease brightness / Backlight On/Off (For APPC 1731T only)

Rear I/O

- Ethernet: 2 x RJ45
- 2nd display VGA port: 1 x DB15
- Audio port: 1 x Line out; 1 x Line in; 1 x MIC-in
- USB: 4 x USB 2.0
- PS2 keyboard/ mouse
- Power switch
- Reset button
- COM #1: RS232/422/485 w/RI or 5V selection

Dimension Drawing

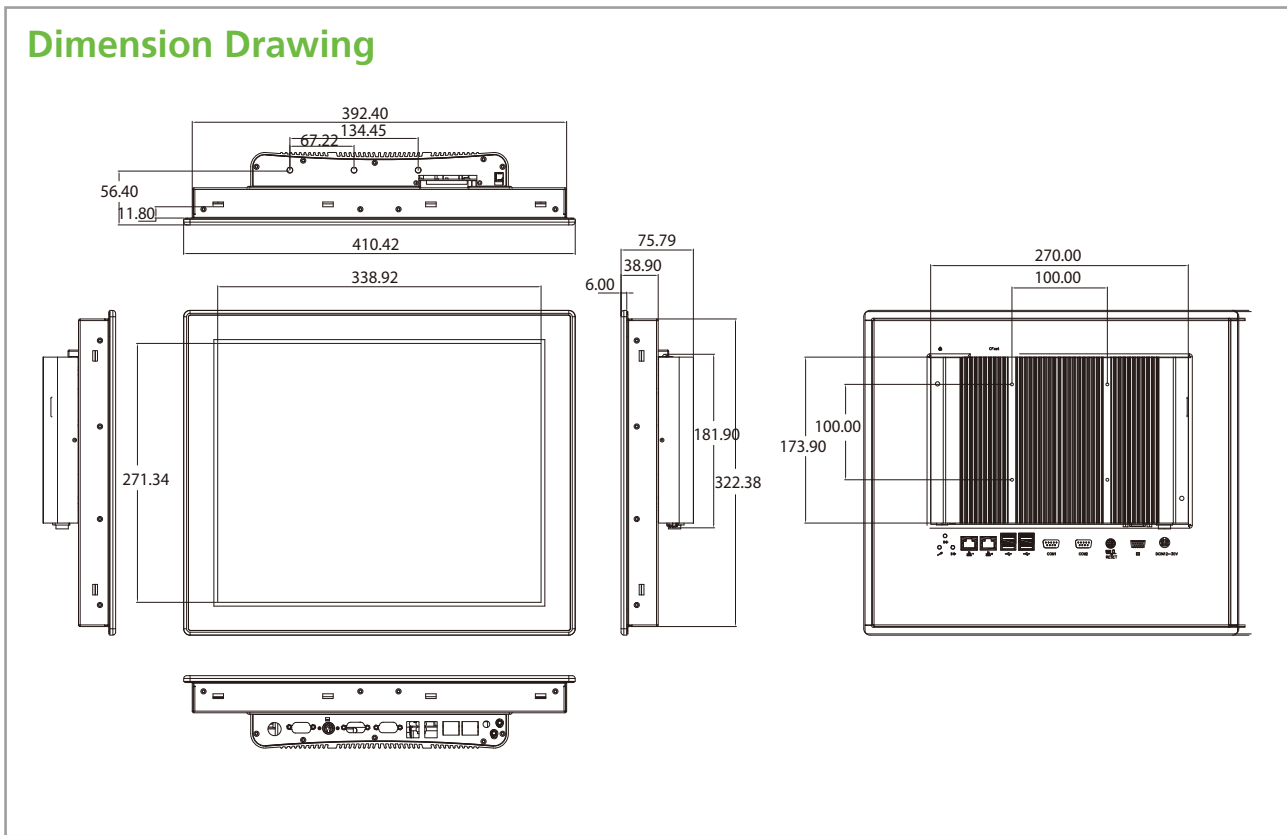

- COM #2: RS232/422/485 w/RI or 12V selection

For APCC1731T only

- DIO w/ 2.5kv isolated:
 - 4x Digital Input (Source type)
 - Input Voltage (Dry Contact): Logic 0: Close to GND
 - Logic 1: Open
 - Input Voltage: Logic 0: 3V max
 - Logic 1: +5V ~ +30V
- 4x Digital Output (Sink type)
 - Output Voltage: 3.6V ~ 5V
 - Sink current: 200 mA max. per channel
- GPIO: 2 x digital in / 2 x digital out
- COM #1: RS232/422/485 w/ 2.5kv isolated
- COM #2: RS232/422/485 w/ 2.5kv isolated
- COM #3: RS232 w/ RI or 5V selection
- COM #4: RS232 w/ RI or 12V selection

Audio

- AC97 codec: Realtek ALC886-GR
- Audio interface: Line out/Line in/MIC-in Audio Jack

Ethernet

- LAN chip: dual Intel® 82574L Gigabit LAN
- Ethernet interface: 10/100/1000 Based-Tx Ethernet compatible

Mechanical & Environment

- Color: pantone blackRAL 15 00 front bezel w/ Pantone 400C\RAL 090 80 10 metal style membrane
- IP protection: IP65 front
- Mounting: panel/ wall/ stand/ VESA 100mm x 100mm
- Power input: 12V~ 30V DC
- Power adapter: Optional AC to DC power adaptor (+12V, 60W)
- Vibration:
 - IEC 68 2-64 (w/ HDD)
 - 1Grms @sine, 5~500Hz, 1hr/axis (HDD Operating)

- 2Grms @sine, 5~500Hz, 1hr/axis (CFast Operating)
- 2.2Grms @ random condition, 5~500Hz, 0.5hr/axis (Non-operating)
- Shock:
 - IEC 68 2-27
 - HDD: 20G@wall mount, half sine, 11ms
- Operating temperature: -5°C to 50°C
- Storage temperature: -20°C to 75°C
- Operating humidity: 10%~90% relative humidity, non-condensing
Limits to be at 90% RH at max 50°C
- Dimension: 410.4 x 340.4 x 75.79 mm
- Weight: 6.6 Kg

Certifications

- CE approval
- FCC Class A

Ordering Information

Barebone

- **APPC 1730T (P/N: 10IA1730T00X0)**
17" SXGA CCFL Backlight Touch Panel PC, Intel® Atom™ D2550
1.86 GHz, touch screen, 1GB DDR3, 2xRS232/422/485
- **APPC 1731T (P/N: 10IA1731T00X0)**
17" SXGA CCFL Backlight Touch Panel PC, Intel® Atom™ D2550
1.86 GHz, touch screen, 1GB DDR3, 2xRS232/422/485 and 2x2 D/I/O
with isolated protection, 2xRS232, 4x4 GPIO, Brightness adjustment
buttons

Options

- **12V, 60W AC/DC power adapter w/o power cord (P/N: 7400060002X00)**